



HERA SPECTRORADIOMETER

—
Specification

ADMESY

colorimeters | spectroradiometers | lightmeters

CONTENTS

- Hera — cost effective spectroradiometer for lighting measurements..... 2
- Highlights..... 2
- Speed & ease of use 3
- Hera general specifications 3
- Hera series specifications..... 4
- Integrating spheres, fibers and OD filters 5
- Speed & performance Hera 01 with AIS 75..... 6
- Speed & performance Hera 01 with AIS 150..... 7
- Speed & performance Hera 01 with AIS 250..... 8
- Hera M8 fiber dimensions..... 9
- Hera cosine corrector dimensions 10

HERA — COST EFFECTIVE SPECTRORADIOMETER FOR LIGHTING MEASUREMENTS

The Hera Series spectroradiometers is ideal for LED measurements where ease of use, stability, performance and price are key factors. Available in three spectral ranges. VIS spectroradiometers ranging from 380 to 780nm (Hera 01) and 360 to 830nm (Hera 02). A UV-NIR with a range of 250 to 1100nm (Hera 04).

For measurements of light sources Admesy offers a range of integrating spheres which can be connected through M8 fiber connections. A fixed position fiber connector has been developed to connect the optical fiber in a fixed and uniform way from calibration to final use. Due to this fixed position measurement results are more stable. Furthermore, the Hera series is available in a variety of optical systems: 5, 10 or 20mm collimating lens or a 1cm² cosine corrector.

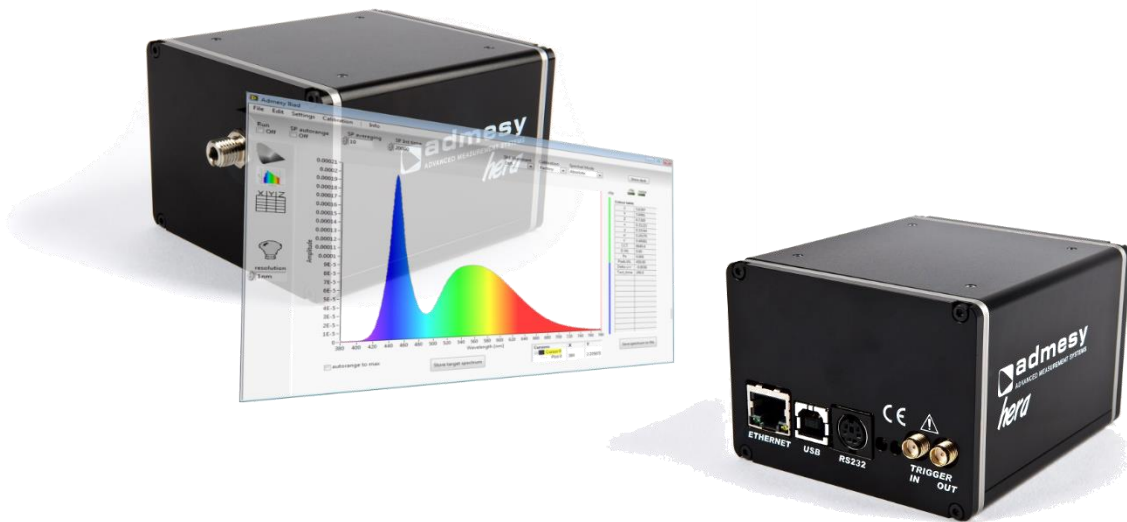

HIGHLIGHTS

- Three spectral ranges including VIS and UV-NIR
- Determines both spectral output and color values
- Auto-range function
- Excellent linearity over entire dynamic range
- Dark current compensated, virtually zero over entire integration range
- Holographic grating for low stray light
- USBTMC compliant, SCPI command set, high speed device
- USB, RS232, Ethernet connections and trigger in & out for ideal system integration
- All calculations are carried out inside the device, saving processing power in production environments
- Robust housing, optimized for mounting and protection in harsh production environments

SPEED & EASE OF USE

Admesy strongly believes in developing and manufacturing devices where ease of use and speed are key factors. In order to achieve these aspects, Admesy considers the following aspects of spectroradiometers to be taken care of.

- Wavelength calibration
- Dark current
- Linearity
- Absolute calibration

Calculations and compensations are done in a staggering 14ms. All this is possible due to the high speed processor inside the Hera combined with algorithms developed for this specific device. In production processes, no external calculation power is needed from computers. Data can be used directly in production settings without any delay of processing data afterwards. This saves time and processing power of the operating system of a production line.

When for example setting the integration time to 10ms, full calibrated spectral data is processed within 24ms. This includes transferring data through high speed USB. This makes the Hera series an ideal LED sorting device where speeds up to 50 LEDs per second can be achieved.

HERA GENERAL SPECIFICATIONS

Hera types 01-04	
Non linearity	< 1 %
Spectral resolution	Selectable 0.5 nm, 1 nm, 2.5 nm, 5 nm or 10 nm
Measurement parameters	Spectral output, radiometric data or color data (Lumen, xy, DWL, PWL, CRI, CCT, etc.)
Data processing time	14 ms
Integration time	2.5 ms – 20 s
Interfaces	High speed USB, RS232, Ethernet, Trigger connections
Size (HxWxD)	95 x 81 x 61 mm (without optical system)
Weight	650 gram
Power consumption	1250 mW
Operating temperature	10-35° C

HERA SERIES SPECIFICATIONS

Hera type	01	02	04
Spectral range	380 – 780 nm	360 – 830 nm	250 – 1100 nm
Optical resolution (FWHM)	2.3 nm	2.3 nm	1.8 nm
Order sorting filter	2nd order sorting on chip	2nd order sorting	Linear variable filter
Wavelength accuracy	±0.5 nm	±0.5 nm	±0.5 nm
Stray light	< 0.2 %	< 0.2 %	< 0.2 %
Lumen accuracy	±4 %	±4 %	±4 %
Chromaticity accuracy	±0.002	±0.002	± 0.002
Luminous flux (AIS 75)	1 m – 60 lm	1 m – 60 lm	1 m – 60 lm
Luminous flux (AIS 150)	5 m – 300 lm	5 m – 300 lm	5 m – 300 lm
Luminous flux (AIS 250)	10 m – 600 lm	10 m – 600 lm	10 m – 600 lm

Notes:

- Specification is subject to change without notification, no legal rights can be derived from this specification.
- Specification of models which are not in production can change.
- Typical value, contact us for different FWHM values.
- After calibration to the calibration standard.
- OD filters can be incorporated for higher ranges into the spheres.
- Stray light measured at 400nm with 455nm cut-off filter with broadband light source.
- Hera 04 type equipped with cosine corrector has typical best response between 250 – 1050nm.
- Calibrations with integrating sphere 360 – 1050nm.

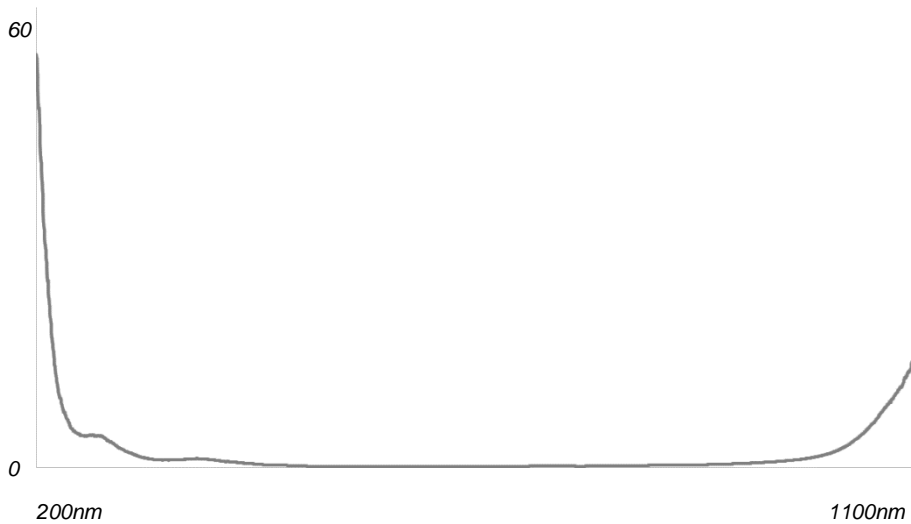

Typical cosine corrector calibration correction factors.

INTEGRATING SPHERES, FIBERS AND OD FILTERS

Admesy offers three integrating sphere sizes. Besides, Admesy can help with customizing integrating spheres for production processes or (re)calibrate integrating spheres. Admesy uses a special M8 fiber connection which has been developed to connect the optical fiber in a consistent way to ensure best possible repeatability.

A higher measurement range can be achieved by implementing neutral density filters (OD filters) in the measurement setup. Admesy offers several OD filters to optimize the Hera for any measurement setup.

Model	Diameter	Auxiliary lamp	Application	Type of DUT
AIS 75	75mm	No	Production	· Standard single LEDs
AIS 150	150mm	Yes	Production, Laboratory	· Standard single LEDs · High power LEDs
AIS 250	250mm	Yes	Laboratory, CIE 127 compliant for 2π measurements	· Standard single LEDs · High power LEDs · Small LED modules



SPEED & PERFORMANCE HERA 01 WITH AIS 75

Measurement conditions	
Used light source	White LED
Integrating sphere size	75mm (AIS 75)
Spectral resolution	1nm
Averaging	1
Auto-range	Off
Temperature	24°

Repeatability at 60 lm				
Saturation level	Integration time ms	Lumen (2sigma)	Chromaticity x,y (2sigma)	Tact time ms
±80%	2.5	< 0.2%	±0.003	16.5

Repeatability at 15 lm				
Saturation level	Integration time ms	Lumen (2sigma)	Chromaticity x,y (2sigma)	Tact time ms
±80%	10	< 0.2%	±0.0003	24
±40%	5	< 0.3%	±0.0004	19
±20%	2.5	< 0.4%	±0.0008	16.5

Repeatability at 5 lm				
Saturation level	Integration time ms	Lumen (2sigma)	Chromaticity x,y (2sigma)	Tact time ms
±80%	32	< 0.2%	±0.0003	46
±40%	16	< 0.3%	±0.0004	30
±20%	8	< 0.4%	±0.0008	22
±10%	4	< 0.7%	±0.0012	18

Repeatability at 1 lm				
Saturation level	Integration time ms	Lumen (2sigma)	Chromaticity x,y (2sigma)	Tact time ms
±80%	160	< 0.2%	±0.0003	174
±40%	80	< 0.3%	±0.0004	94
±20%	40	< 0.4%	±0.0008	54
±10%	20	< 0.7%	±0.0012	34

Repeatability at 0.1 lm				
Saturation level	Integration time ms	Lumen (2sigma)	Chromaticity x,y (2sigma)	Tact time ms
±80%	1600	< 0.2%	±0.0003	1614
±40%	800	< 0.3%	±0.0004	814
±20%	400	< 0.4%	±0.0008	414
±10%	200	< 0.7%	±0.0012	214

Measurements are real life taken and may vary slightly from device to device.

SPEED & PERFORMANCE HERA 01 WITH AIS 150

Measurement conditions	
Used light source	White LED
Integrating sphere size	150mm (AIS 150)
Spectral resolution	1nm
Averaging	1
Auto-range	Off
Temperature	24°

Repeatability at 300 lm				
Saturation level	Integration time ms	Lumen (2sigma)	Chromaticity x,y (2sigma)	Tact time ms
±80%	2.5	< 0.2%	±0.003	16.5

Repeatability at 75 lm				
Saturation level	Integration time ms	Lumen (2sigma)	Chromaticity x,y (2sigma)	Tact time ms
±80%	10	< 0.2%	±0.0003	24
±40%	5	< 0.3%	±0.0004	19
±20%	2.5	< 0.4%	±0.0008	16.5

Repeatability at 25 lm				
Saturation level	Integration time ms	Lumen (2sigma)	Chromaticity x,y (2sigma)	Tact time ms
±80%	32	< 0.2%	±0.0003	46
±40%	16	< 0.3%	±0.0004	30
±20%	8	< 0.4%	±0.0008	22
±10%	4	< 0.7%	±0.0012	18

Repeatability at 5 lm				
Saturation level	Integration time ms	Lumen (2sigma)	Chromaticity x,y (2sigma)	Tact time ms
±80%	160	< 0.2%	±0.0003	174
±40%	80	< 0.3%	±0.0004	94
±20%	40	< 0.4%	±0.0008	54
±10%	20	< 0.7%	±0.0012	34

Repeatability at 0.5 lm				
Saturation level	Integration time ms	Lumen (2sigma)	Chromaticity x,y (2sigma)	Tact time ms
±80%	1600	< 0.2%	±0.0003	1614
±40%	800	< 0.3%	±0.0004	814
±20%	400	< 0.4%	±0.0008	414
±10%	200	< 0.7%	±0.0012	214

Measurements are real life taken and may vary slightly from device to device.

SPEED & PERFORMANCE HERA 01 WITH AIS 250

Measurement conditions	
Used light source	White LED
Integrating sphere size	250mm (AIS 250)
Spectral resolution	1nm
Averaging	1
Auto-range	Off
Temperature	24°

Repeatability at 600 lm				
Saturation level	Integration time ms	Lumen (2sigma)	Chromaticity x,y (2sigma)	Tact time ms
±80%	2.5	< 0.2%	±0.003	16.5

Repeatability at 150 lm				
Saturation level	Integration time ms	Lumen (2sigma)	Chromaticity x,y (2sigma)	Tact time ms
±80%	10	< 0.2%	±0.0003	24
±40%	5	< 0.3%	±0.0004	19
±20%	2.5	< 0.4%	±0.0008	16.5

Repeatability at 50 lm				
Saturation level	Integration time ms	Lumen (2sigma)	Chromaticity x,y (2sigma)	Tact time ms
±80%	32	< 0.2%	±0.0003	46
±40%	16	< 0.3%	±0.0004	30
±20%	8	< 0.4%	±0.0008	22
±10%	4	< 0.7%	±0.0012	18

Repeatability at 10 lm				
Saturation level	Integration time ms	Lumen (2sigma)	Chromaticity x,y (2sigma)	Tact time ms
±80%	160	< 0.2%	±0.0003	174
±40%	80	< 0.3%	±0.0004	94
±20%	40	< 0.4%	±0.0008	54
±10%	20	< 0.7%	±0.0012	34

Repeatability at 1 lm				
Saturation level	Integration time ms	Lumen (2sigma)	Chromaticity x,y (2sigma)	Tact time ms
±80%	1600	< 0.2%	±0.0003	1614
±40%	800	< 0.3%	±0.0004	814
±20%	400	< 0.4%	±0.0008	414
±10%	200	< 0.7%	±0.0012	214

Measurements are real life taken and may vary slightly from device to device.

HERA M8 FIBER DIMENSIONS

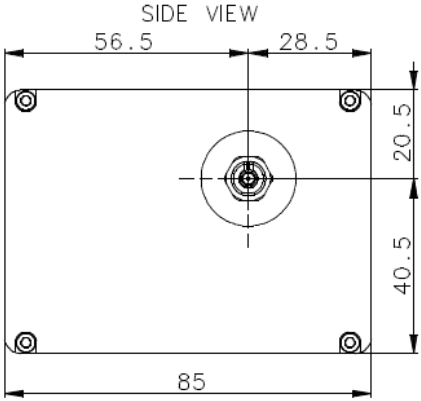
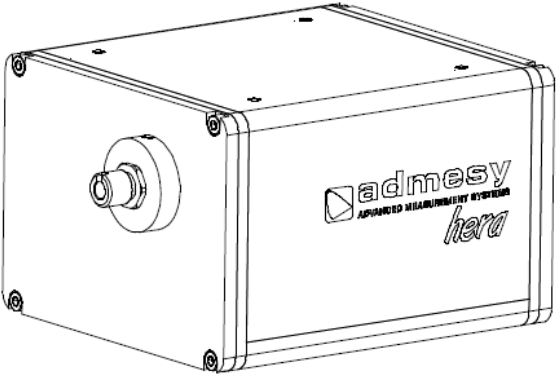
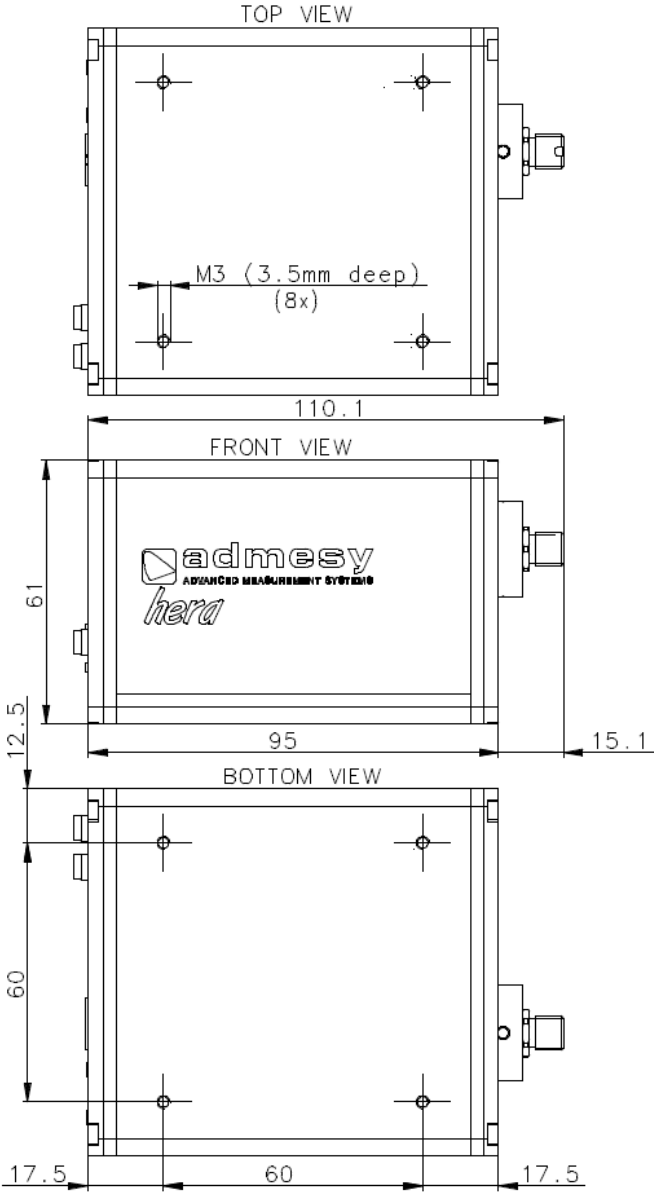

HERA COSINE CORRECTOR DIMENSIONS

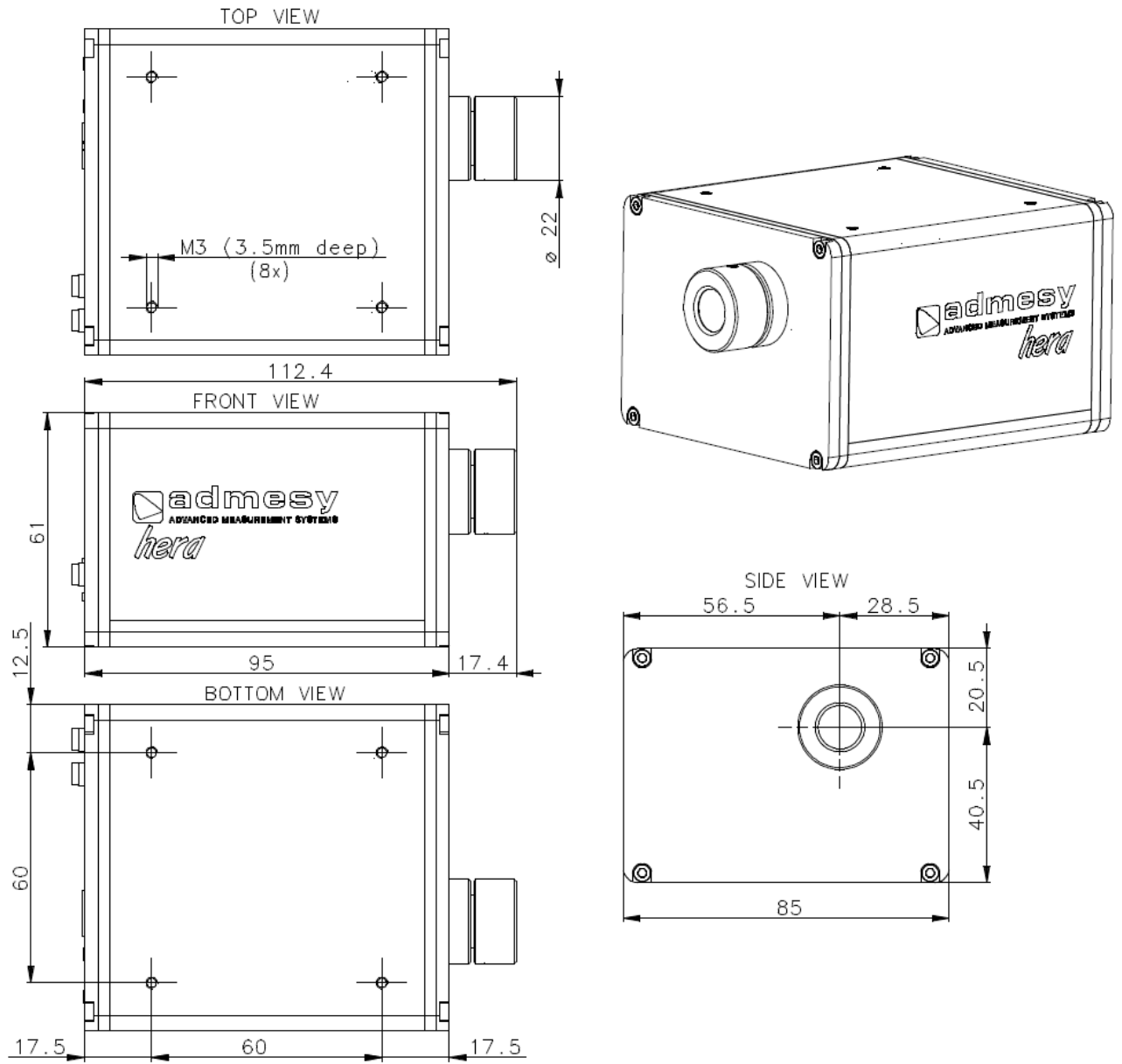

ADMESY

colorimeters | spectroradiometers | lightmeters

Sleestraat 3
6014 CA IJltervoort
The Netherlands

+31 (0)475 600 232
info@admesy.com

admesy.com

The material in this document is subject to change. No rights can be derived from the content of this document. All rights reserved. No part of this document may be reproduced, stored in a database or retrieval system, or published in any form or way, electronically, mechanically, by print, photo print, microfilm or any other means without prior written permission from the publisher.

Version 1.1 January 2022